

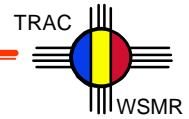

Field Experiment Validation using CASTFOREM



Validation of a Live-Virtual Field Experiment using Constructive Simulation

Paul J. Deason, Ph.D.

U.S. Army TRADOC Analysis Center - WSMR
White Sands Missile Range, New Mexico USA



Field Experiment Validation Using CASTFOREM

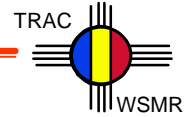

Contents

- A Word about our Sponsor
- Purpose of the Field Experiment
- Purpose of the Validation
- Field Experiment Details
- Constructive Simulation Validation
- Conclusions



Rapid Force Projection Initiative Concept

The RFPI Advanced Concept Technology Demonstration (ACTD) is an effort sponsored by the Office of the Secretary of Defense to improve the combat capability of early entry forces. Because early entry forces are usually built around light infantry for strategic mobility, they may be vulnerable to threat armor and indirect fire. The RFPI Hunter-Stand-off Killer concept was developed to reduce this vulnerability using long range precision sensors and weapons systems with digital command and control systems so that the enemy can be defeated before decisively engaging our early entry force. This is an application of current Army doctrine of extending and dominating battlespace but requires improvements in target acquisition, lethality, survivability, and control of battle tempo.



Field Experiment Validation Using CASTFOREM

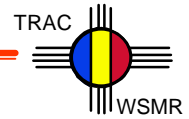

Purpose of the RFPI Field Experiment

- While using the developmental System of Systems, the Field Experiment provided live situational action, battle flow, and produced the “collective” of human action and will.
- The Live-Virtual nature of the Field Experiment allowed humans to interact with developmental weapons, sensors, and communications
- The Live- Virtual Field Experiment methodology allowed the development and rehearsal of Tactics, Techniques, and Procedures concerning the utility and integration of developmental systems into the real systems mix.



Field Experiment Validation Using CASTFOREM

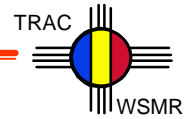

Objectives of Live/Virtual Field Experiment Architecture

Expand the Live Fight to Blue Division-ready Brigade Versus Red Division

- Represent entire compliment of live and virtual entities in virtual domain
 - Live-on-Live; Virtual-on-Live; Live-on-Virtual; Virtual-on-Virtual

Enable Interaction of Live and Virtual Entities

- Represent all munitions firing, detonations, and casualties in the virtual domain
- Inform live entities of their damage status
- Reflect direct-fire MILES casualties in the virtual domain
- Synchronize live and virtual target acquisitions and battlefield damage assessments
- Transition one virtual battalion of OPFOR to live OPFOR at the range boundary
- Interface with live OPFOR voice networks

Stimulate Brigade C4I

- Represent critical virtual OPFACs to participate on tactical voice networks
- Represent critical virtual OPFACs to participate on tactical VMF network
- Stimulate ATCCS systems to the degree supported by existing stimulation tools

Support Exercise Control, Data Collection, and Analysis

- Interface virtual environment Observer/ Controllers to live Observer/Controller's voice network
- Accumulate and display battle views and statistics
- Integrate with experimental control and instrumentation control via voice and digital nets

DO ALL OF THE ABOVE IN REAL-TIME!



Field Experiment Validation Using CASTFOREM

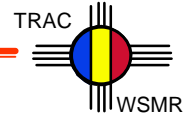

Purpose of the Field Test Validation

- By ACTD charter, a result of the Field Experiment was the recommendation for retention by the EXFOR of experimental hardware.
- The live-virtual nature of the Field Experiment design was intended to create the situation where the live EXFOR unit was required to react realistically to a much larger Opposition Force than could have physically been present, with live elements seamlessly integrated, portraying realistically direct and indirect fire systems and intelligence systems, both TOE and in development, which otherwise could not have been used force-on-force except in war.



Field Experiment Validation Using CASTFOREM

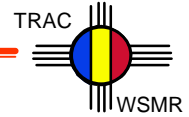

Purpose of Constructive Simulation Validation of the Live-Virtual Field Experiment

- Constructive simulations like CASTFOREM have been in use for decades to allow the evaluation of systems' effectiveness in force-on-force settings. They are validated for this purpose.
- Validation of the Live-Virtual Field Experiment with constructive simulation would allow a mantle of reproducibility /applicability/ external validity to the Field Experiment.
- Representation of the Field Experiment in CASTFOREM would allow extensions and examinations of the Field Experiment impossible in situ. For instance:
 - The creation of a Analytic Base Case
 - The creation of alternatives examining different mixes of systems
 - The alteration of environmental conditions
- Representation in CASTFOREM would allow the isolation and identification of problem areas.



Field Experiment Validation Using CASTFOREM

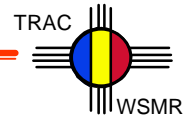

Experimental Issues in the RFPI ACTD

- As compared to the analytical baseline force, is the RFPI-equipped task force more survivable?
- As compared to the analytical baseline force, is the RFPI-equipped task force more lethal?
- As compared to the analytical baseline force, does the RFPI-equipped task force have increased target acquisition capabilities?
- As compared to the analytical baseline force, does the RFPI-equipped task force have an increased control of battle tempo?



Field Experiment Validation Using CASTFOREM

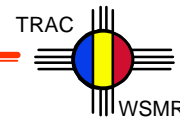

RFPI ACTD Field Experiment

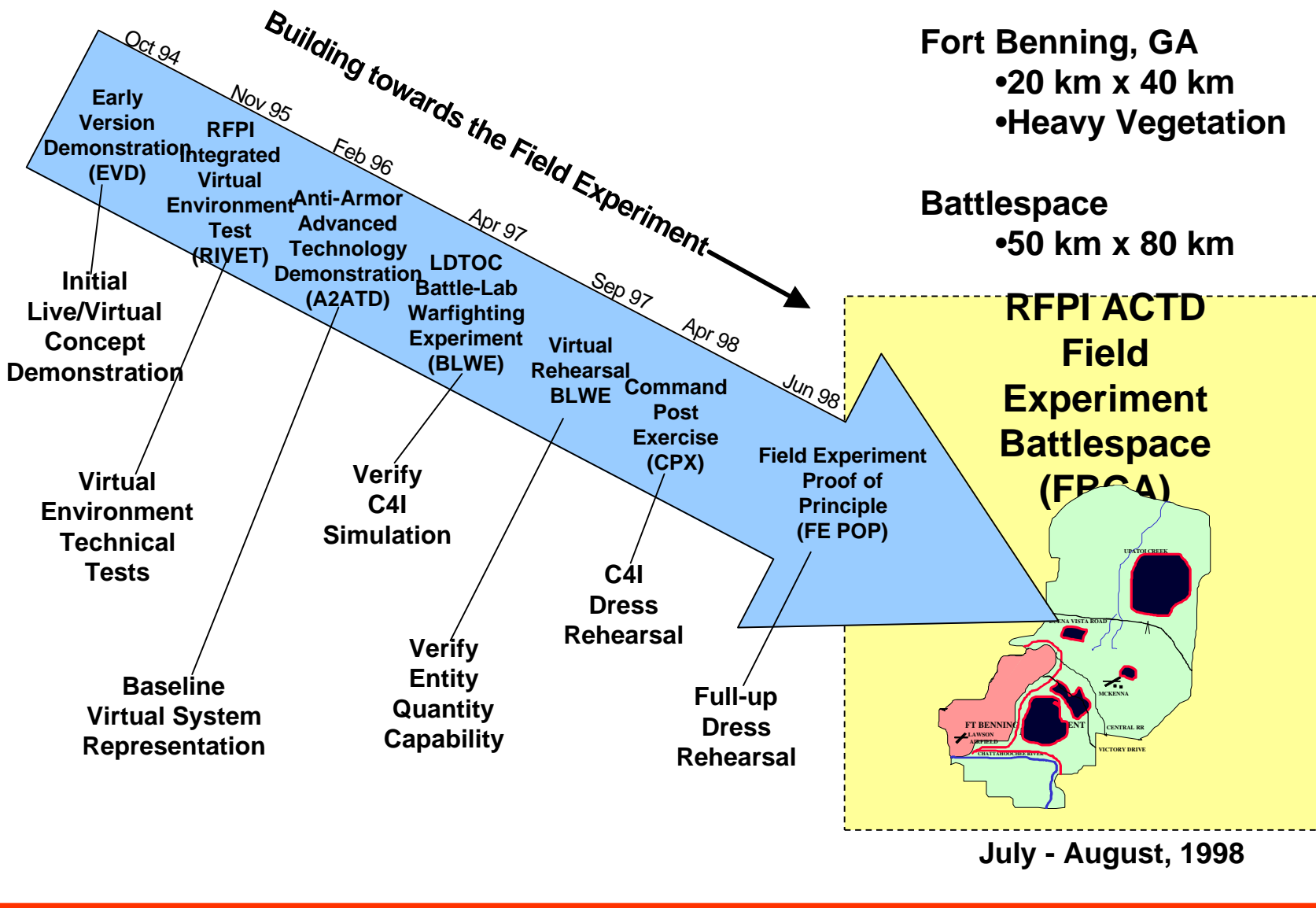



Field Experiment Validation Using CASTFOREM

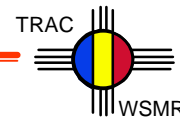

GIVENS

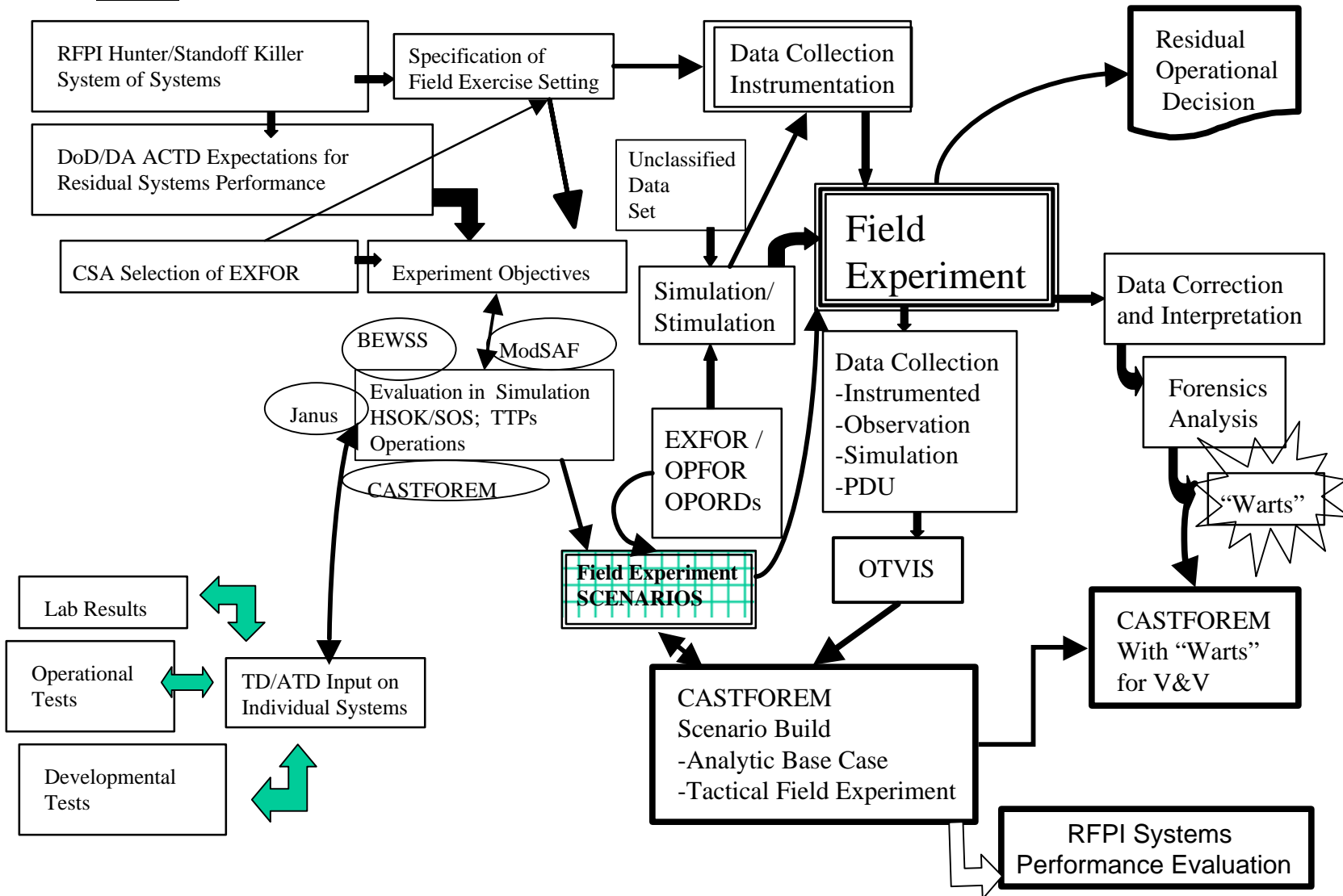



Field Experiment Validation Using CASTFOREM

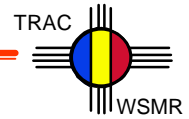

Experimental Scenario Overview

General Situation: The United States has been asked to provide military assistance to a small country torn by civil war and whose neighbor to the north has seized this opportunity to launch an invasion. The US has dispatched a Division Ready Brigade (DRB) from the 101st ABN (AA) Division to assist the friendly forces in defending against the invasion. In the course of the campaign, the US forces (in conjunction with other friendly forces) will conduct a Defense in Sector to halt the invasion wave (a Mechanized Infantry Division (-)), conduct an attack to seize a village/airfield for use in establishing a Forward Operating Base (FOB), conduct a Hasty Defense Of the FOB to defend against a Threat Counterattack (Mechanized Infantry BDE (+)), and transit to a Deliberate Defense of FOB to defend against the second invasion wave (Mechanized Infantry Division (-)).

Three scenarios were developed on Fort Benning, GA, terrain for the RFPI ACTD.

Defense In Sector of a Tactical Assembly Area

Hasty Defense of Forward Operating Base

Deliberate Defense of Forward Operating Base.



RFPI Ft. Benning Field Experiment Forces

- The Blue unit was a reinforced air assault infantry brigade
 - about one-fifth were represented live at Ft. Benning, four-fifths virtual, represented in simulation
 - Command, control, computers, communications and intelligence (C4I) nodes were live
 - Most RFPI-specific sensors and shooters were represented live, or live-in-simulation (for firing)
- The Threat was a mechanized infantry division
 - Nine tanks, 28 APCs and five trucks were live; the rest were in simulation.



Field Experiment Validation Using CASTFOREM

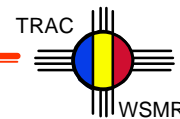

Inequality of Force Distribution

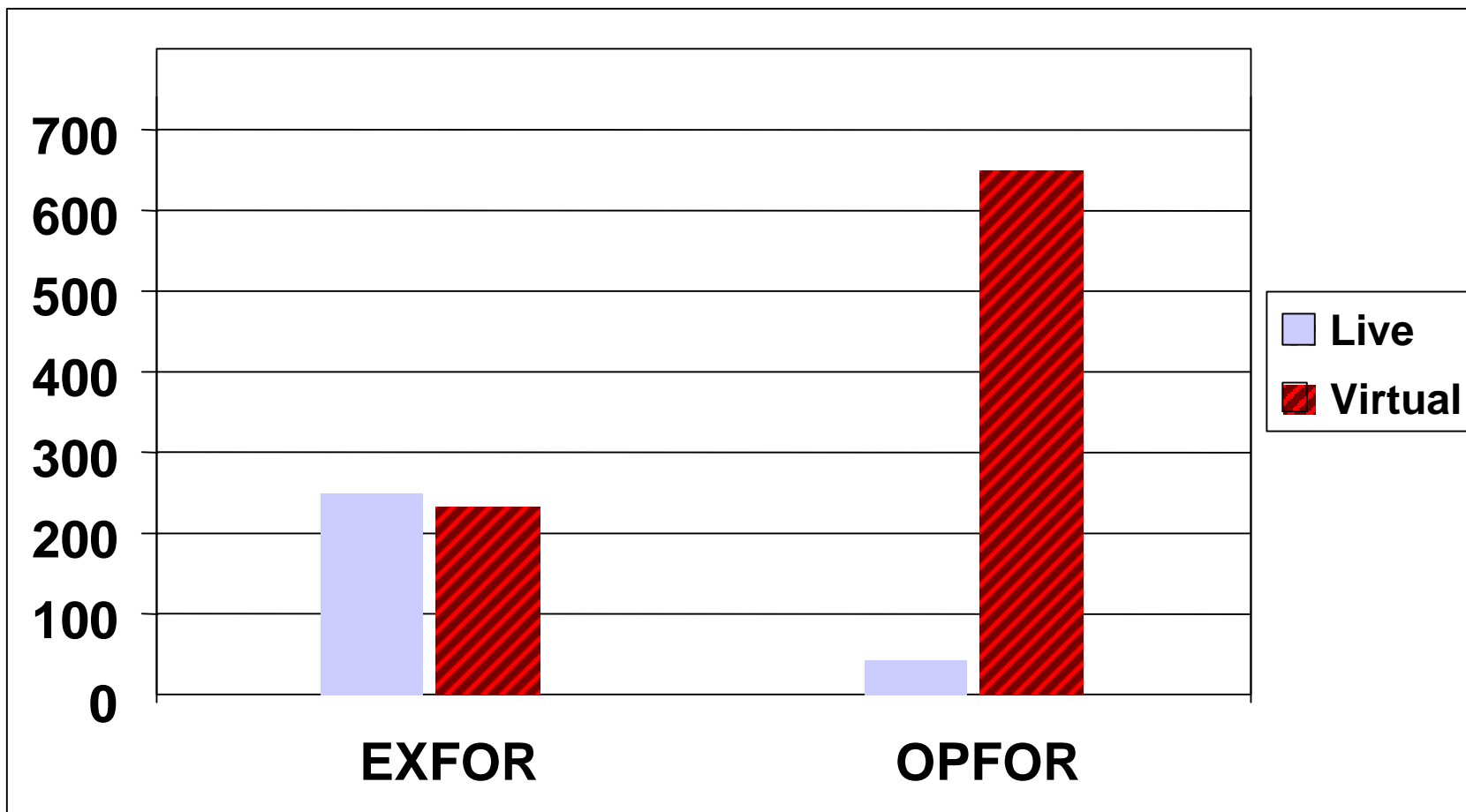

Due to the small number of Live OPFOR, extensive interactions with both Live and Virtual OPFOR systems was required to fully exercise the Live RFPI systems



Assumptions

- The guidance received from 2nd/101st AASLT accurately represented the unit's tactical employment and the RFPI systems' operational use
- Weapon systems and targets are accurately and adequately represented:
 - Data
 - Simulators/Simulations
 - Live-virtual interactions
- Constructive simulation can represent this reality
- There will be a recurrent need to represent live/virtual field exercises in constructive simulation.



Field Experiment Validation Using CASTFOREM

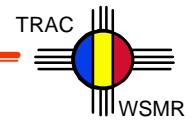

Progression toward Field Experiment Validation

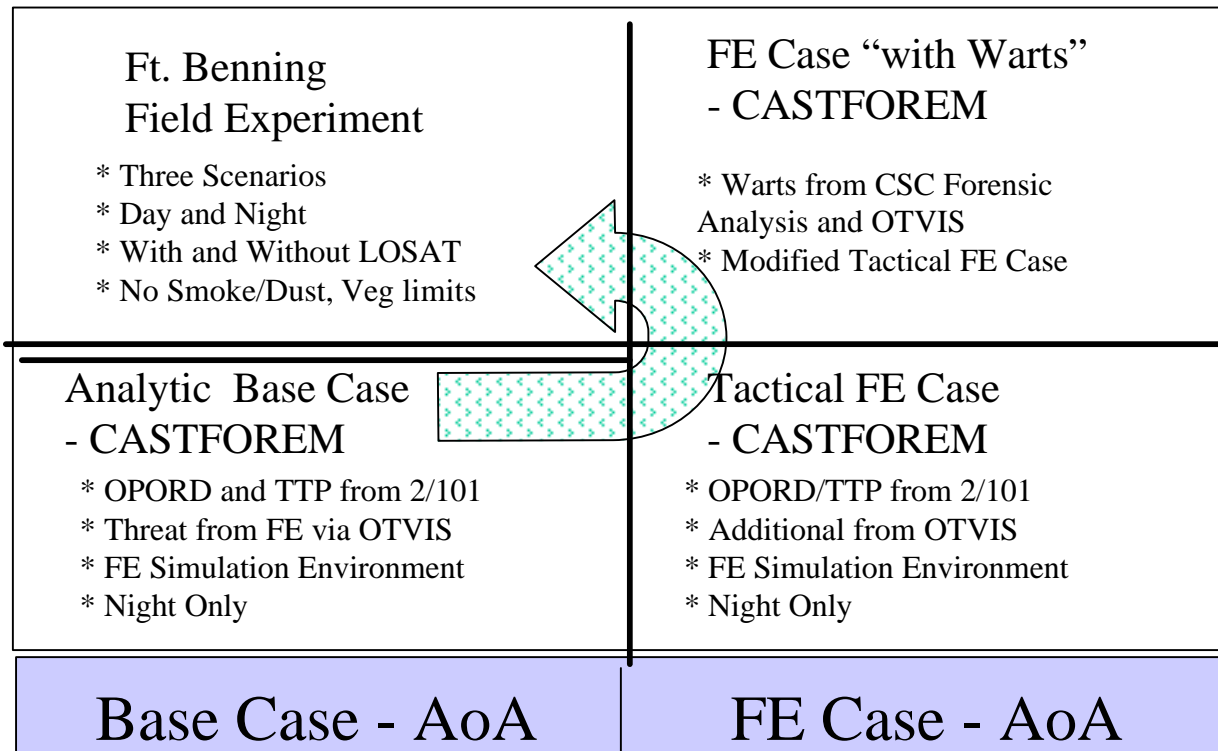

FE Unclassified Data;
CASTFOREM Classified and Unclassified Data Sets



Field Experiment Scenarios, All with RFPI Equipment

- **Field Experiment Scenario Settings** (with good data)
 - 31 July - Defense in Sector, Night, with LOSAT
 - 3 August - Hasty Defense, Night to Day
 - 5 August - Deliberate Defense, Day
 - 6 August - Deliberate Defense, Day with LOSAT
 - 7 August - Deliberate Defense, Night
- **CASTFOREM Analytic Base Case** for each of the three scenario settings
- **CASTFOREM Tactical FE** - Five Scenarios
 - Defense in Sector, Night, with and without LOSAT
 - Hasty Defense, Night
 - Deliberate Defense, Night, with and without LOSAT



Field Experiment Validation Using CASTFOREM

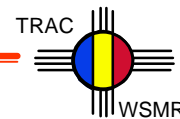

Environment at Ft. Benning	Analytic Base Cases	Tactical Field Experiment Representation
Day <u>or</u> Night	Defense in Sector	Defense in Sector
Smoke and Dust <u>or</u> No Smoke and Dust		Defense in Sector with LOSAT
See-through trees for helicopters <u>or</u> helicopter LOS blocked by vegetation	Hasty Defense of the FOB	Hasty Defense of the FOB
Classified (“Standard”) data <u>or</u> unclassified (“Nominal”) data	Deliberate Defense of the FOB	Deliberate Defense of the FOB
FE workarounds (“WARTS”) <u>or</u> realistic tactical play		Deliberate Defense of the FOB with LOSAT



Excursions in CASTFOREM to Enhance Applicability

- Represented Vegetation, Dust and Smoke
 - Due to limitations in the virtual FE simulations/simulators, dust and smoke were not played
 - To represent Apache Longbow in virtual FE, vegetation effects were not played against Helicopter sensors
- Represented Day and Night
 - The number of FE runs was limited, so both day and night played in CASTFOREM
- Dismounted represented throughout
 - Individuals were not represented in the virtual FE
 - Critical to examining survivability of the light force.



Field Experiment Validation Using CASTFOREM

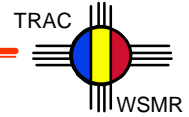

Conclusions

- The Live-Virtual Field Experiment was able to portray a DRB vs. Division fight in real time, and collect meaningful information from it.
- It was possible to represent the Field Experiment Scenarios in CASTFOREM.
- The field experiments into constructive simulation process will be a recurring requirement.
- Improving the process is imperative.



Field Experiment Validation Using CASTFOREM

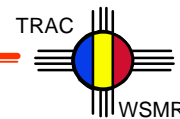

BACKUP



Scenario Development

- Original concept for BLUE Force Base Case provided by BDE S-3 (MAJ Haskins), 2nd BDE/101st ABN (AA) following the RFPI Field Experiment (FE). Operational Concept for RFPI/LOSAT Cases taken from the Field Experiment OPORDs. All cases were supplemented by DIS Data Logger Files from the Field Experiment scenario executions, using OTVIS to review playbacks and generate initial positions and movement data.

Airlift assets that were used for HIMARS and EFOGM in the RFPI case are used to transport an additional two 155mm batteries in the Base Case, giving the DRB a total of three 155mm batteries.

RFPI system TTPs were drawn from interviews with RFPI ACTD participants, observations during the Field Experiment, and project management offices.

- THREAT concept/guidance was provided by RFPI FE OPFOR Cell (Ernie Savage (USAIC) & Charlie Derrick (Quality Research, Inc.)), supplemented by the Distributed Interactive Simulation (DIS) Data Logger Files from the Field Experiment execution.
- CASTFOREM version developed by Paul Deason (TRAC-WSMR RFPI Project Leader) Charles Miller (Blue Force), Ben Ramirez (THREAT), Richard Weber (All Arty), Dale Quinnell (Data Research/Graphics Support), and Jerry Powell (AST) (Scenario Coordination).



Field Experiment Validation Using CASTFOREM

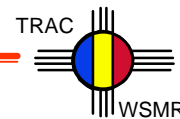

Defense In Sector

Division Ready Brigade (DRB) from 101st ABN (AA) defends in sector against THREAT Mechanized Division (-) on Fort Benning, GA, terrain.*

BLUE RFPI Case

20 Atk Helos (AH-64)
8 OH-58 Helo
14 CAS (A-10)
120 HMMWV (CDR/TOC/SPT)
84 AT(48 TOW2B/36 Javelin)
427 Infantry (378 w/AT4s)
24 ADA (Stinger/Avenger)
12 EFOGM
4 Hunter Sensor Suite
4 Remote Sentry
7 IAS (not in force ratio)
8 155mm AH
18 105mm HOW
3 HIMARS
20 Mortars (60/81mm)
46 Utility Helo (UH-60/CH-47)
3 CMCB Radar
3 GBS

THREAT

9 Atk Helos (Hokum)
6 CAS (Frogfoot)
355 BMP2/MTLB/BTR/BRDM
131 T-72s
36 ADA (2S6/SA-13)
108 SP HOW (122/152mm)
30 MRL (180/220/300mm)
36 SP Mortars (2S12)
2 CMCB Radar

TOTAL THREAT: 713
TOTAL BLUE: 818

* Summer night, helos “see thru” vegetation, no smoke.



Field Experiment Validation Using CASTFOREM

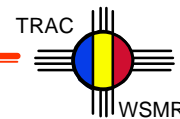

Defense In Sector

Division Ready Brigade (DRB) from 101st ABN (AA) defends in sector against THREAT Mechanized Division (-) on Fort Benning, GA, terrain.*

BLUE Base Case

20 Atk Helos (AH-64)
8 OH-58 Helo
14 CAS (A-10)
123 HMMWV (CDR/TOC/SPT)
84 AT(48 TOW2B/36 Javelin)
427 Infantry (378 w/AT4s)
24 ADA (Stinger/Avenger)
18 105mm TWD HOW
24 155mm TWD HOW
20 Mortars (60/81mm)
3 GBS
3 CMCB Radar
46 Utility Helo (UH-60/CH-47)

THREAT

9 Atk Helos (Hokum)
6 CAS (Frogfoot)
355 BMP2/MTLB/BTR/BRDM
131 T-72s
36 ADA (2S6/SA-13)
108 SP HOW (122/152mm)
30 MRL (180/220/300mm)
36 SP Mortars (2S12)
2 CMCB Radar

TOTAL THREAT: 713
TOTAL BLUE: 814

* Summer night, helos “see thru” vegetation, no smoke.



Field Experiment Validation Using CASTFOREM

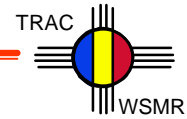

Classical Live / Virtual Architectures

TRAINING

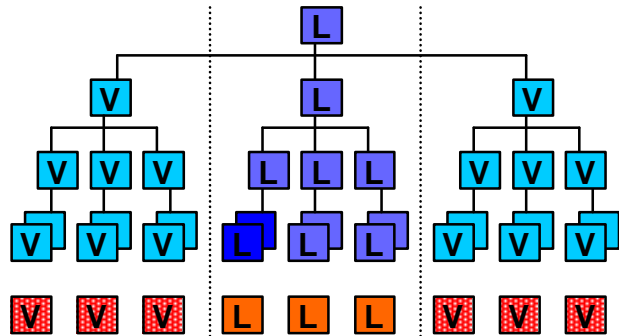

Blue/Red balanced numbers, no cross-interactions

DEMONSTRATION

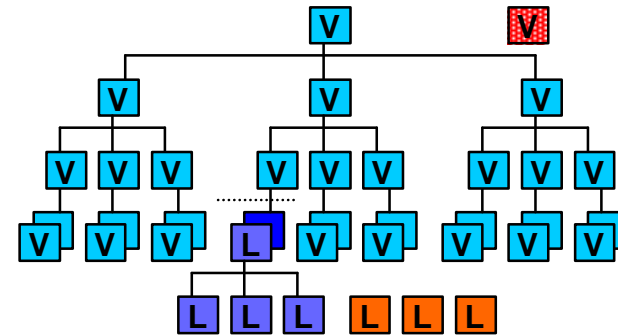

Limited live entities, surrounded by simulation

STIMULATION

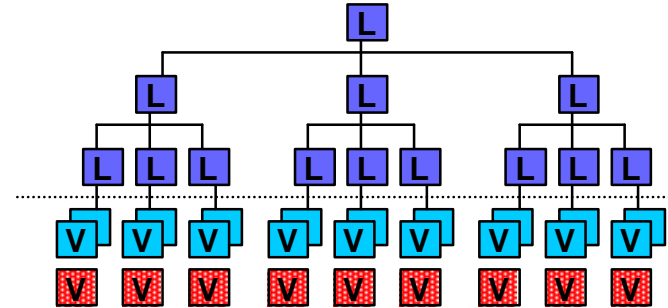

Live command cells stimulated by simulated battle

- Virtual or Constructive Simulation
- Interface
- Live Entities

Typical Live / Virtual Architectures have a clean dividing line between the Live and Virtual entities, but do not provide the complex interactions needed to meet RFPI requirements



Field Experiment Validation Using CASTFOREM



RFPI EXFOR Live / Virtual Architecture

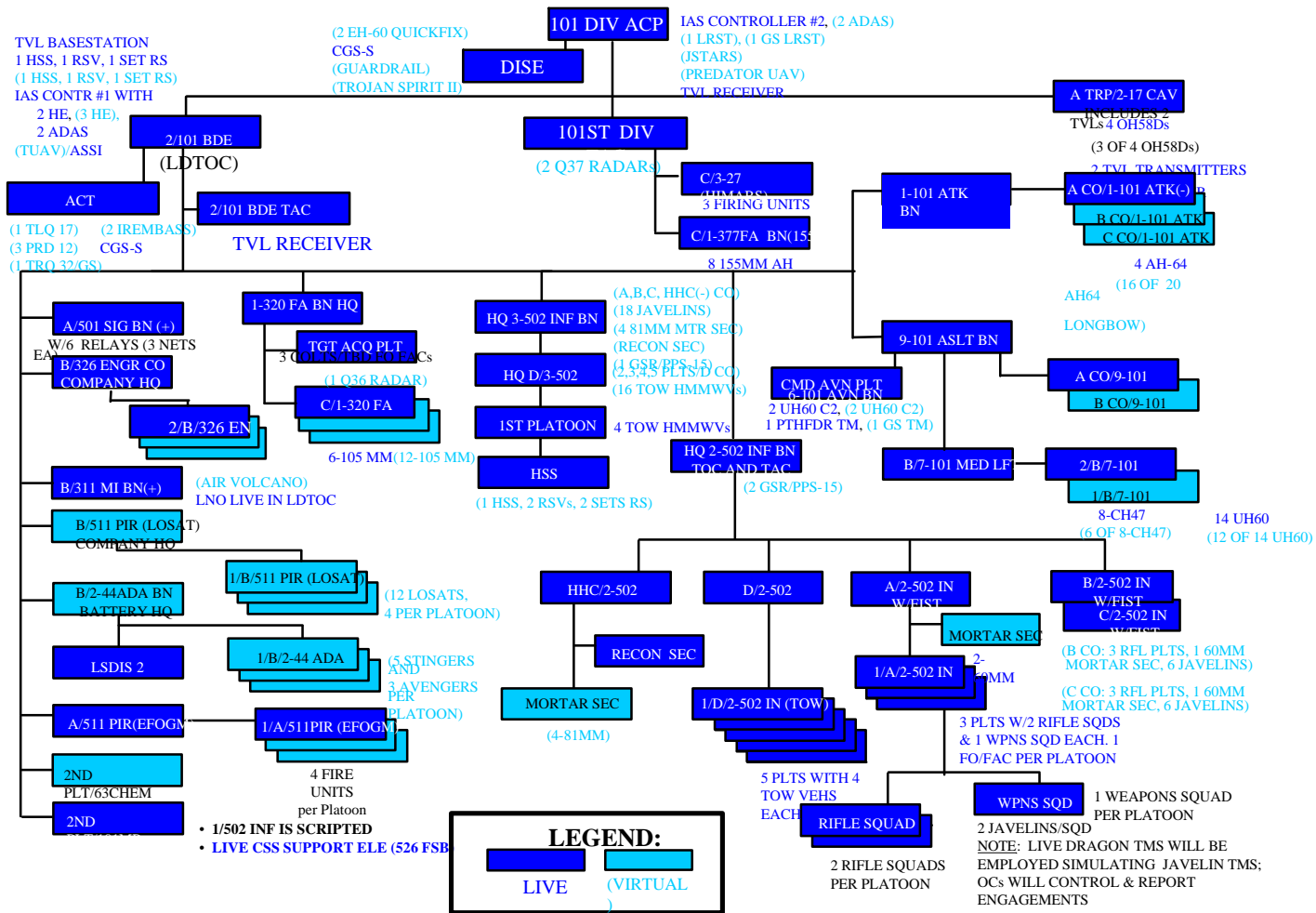

The RFPI Live / Virtual Architecture does not have a clean dividing line between the Live and Virtual entities



Field Experiment Validation Using CASTFOREM

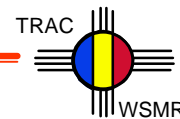

RFPI MODEL - EXPERIMENT - MODEL (M-E-M)
ANALYTICAL PROCESS

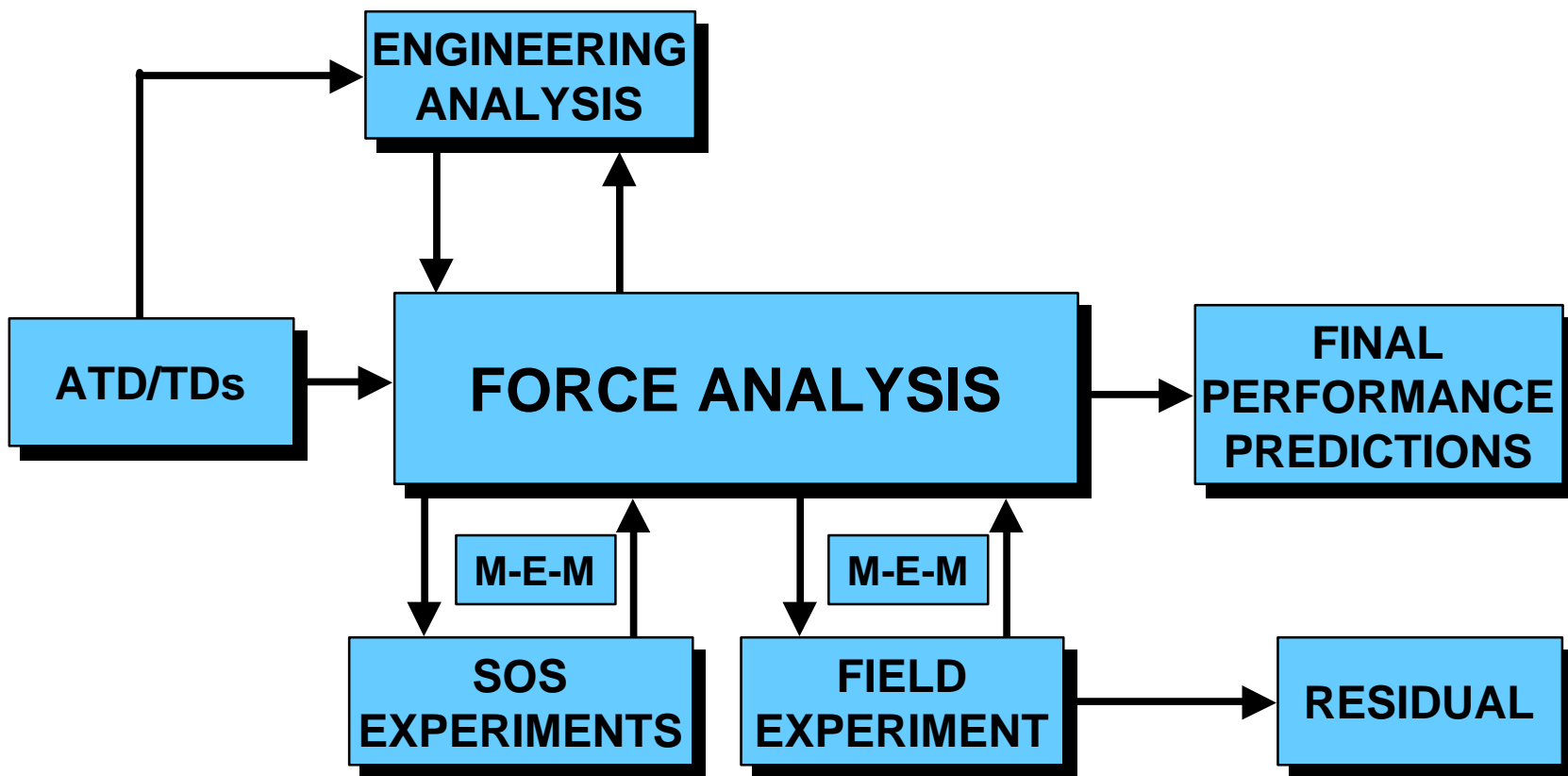



Field Experiment Validation Using CASTFOREM

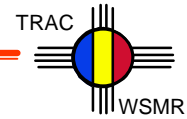

Split Functionality of Live Entities

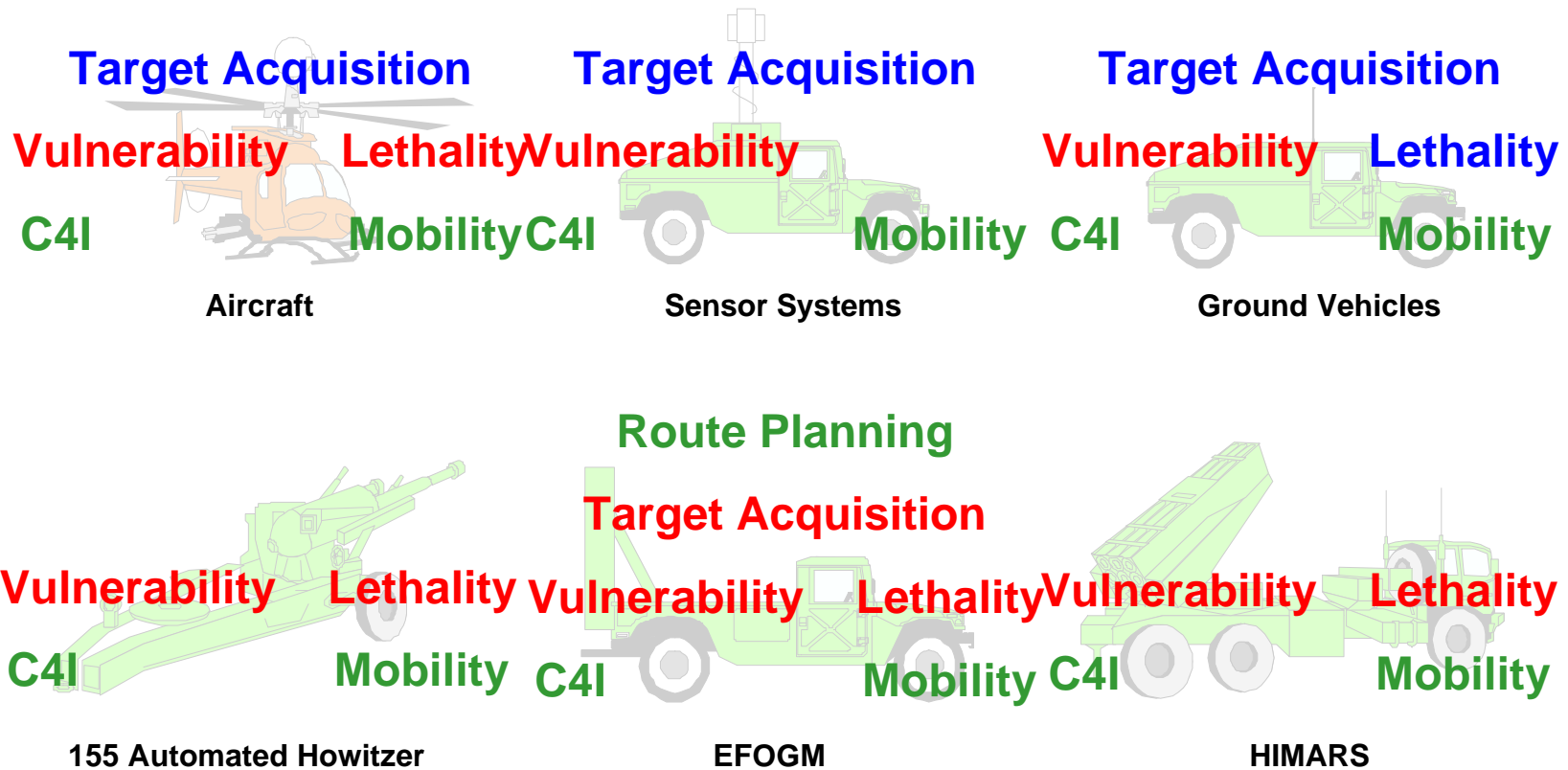

Legend :
Live
Shadow
Both



Field Experiment Validation Using CASTFOREM



Live / Virtual Interaction Approach

"SHADOW SERVER" FUNCTIONS - SOLID ARROWS

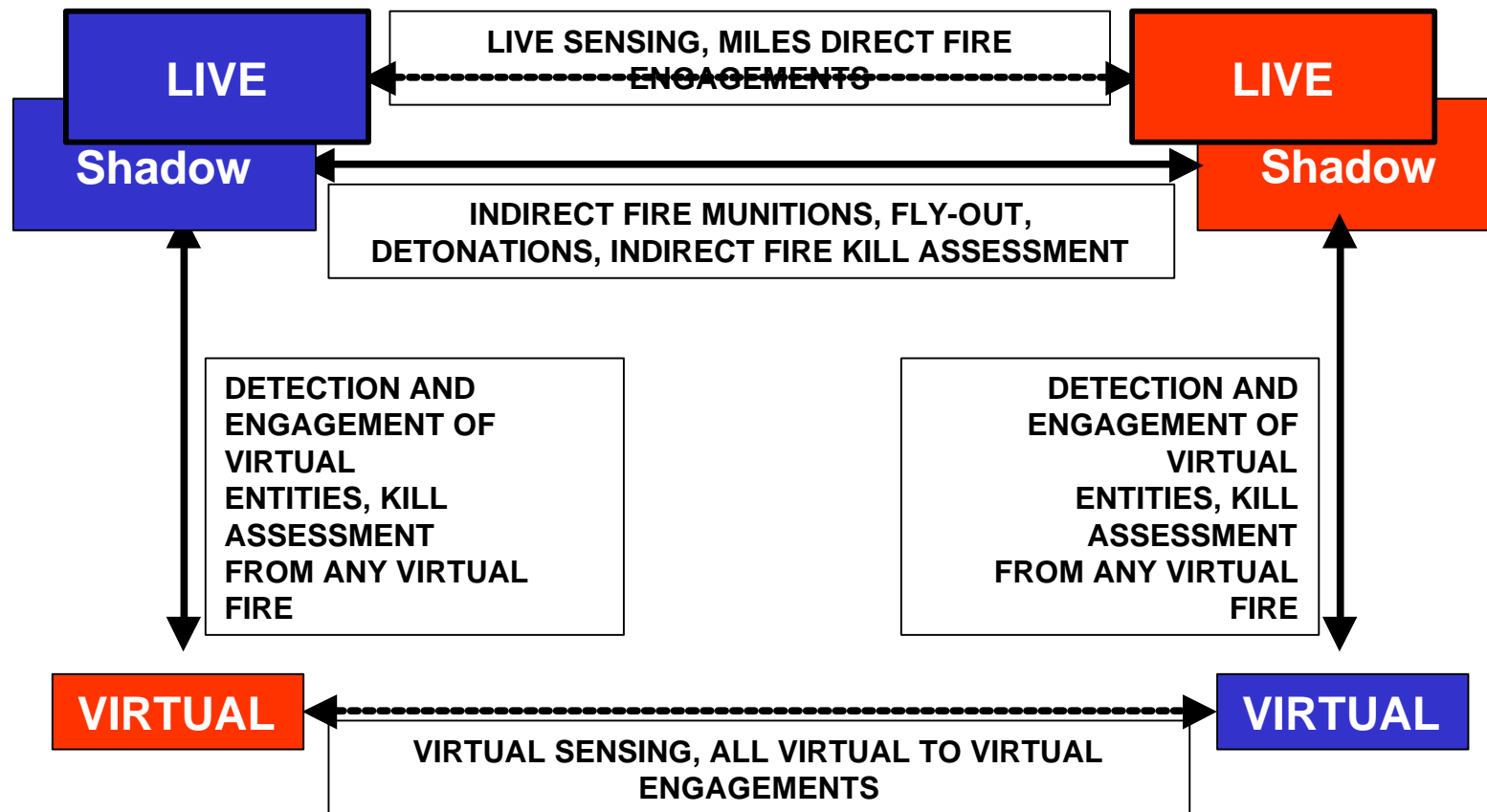



Field Experiment Validation Using CASTFOREM

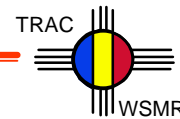

RFPI SIMULATION ARCHITECTURE

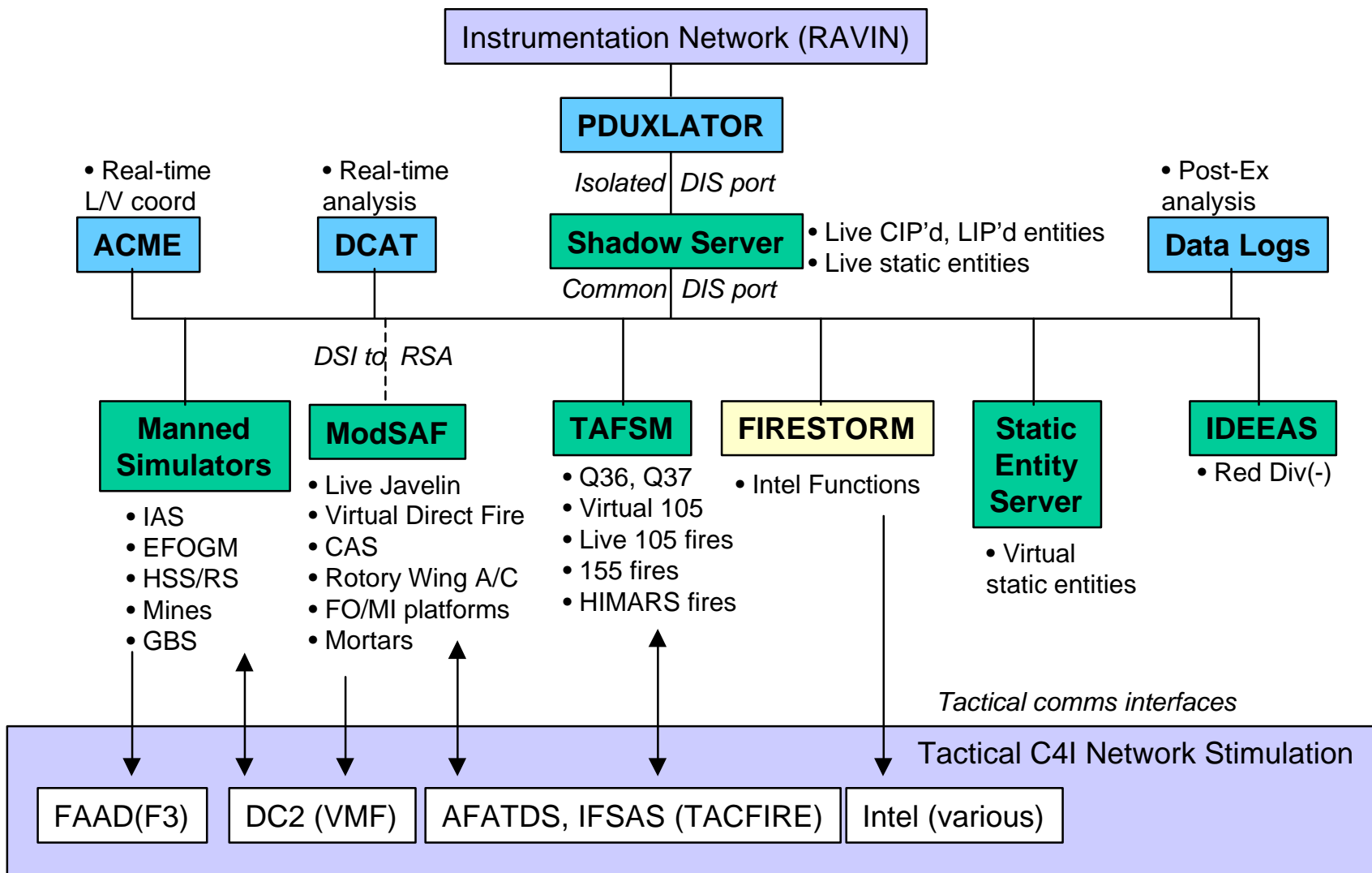

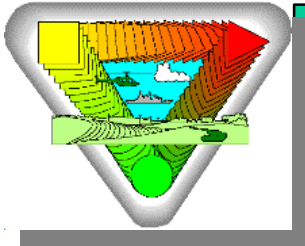

MRDEC LIVE/VIRTUAL SIMULATION

DEVELOPED SIMULATION CAPABILITIES ENABLING RAPID FORCE PROJECTION INITIATIVE (RFPI) LIVE / VIRTUAL EXPERIMENTS

- Interfaced live instrumentation to Distributed Interactive Simulation (DIS) backbone
- DIS integration of >1500 entities, combined live and virtual
- Developed “Shadow Server” concept to allow live/virtual interactions
- Shadow Server transitions virtual to live *real-time* across range boundaries
- Virtual C4I systems stimulate TFXXI digital networks
- Demonstrated first and only DIS Air Assault scenario
- Demonstrated portability to provide DIS battle to remote facilities
- Multiple models (ModSAF, TAFSM, IDEEAS, FIRESTORM, ITEMS) interoperable
- Analysis tools monitor Measure of Effectiveness (MOEs) *real-time* in experiments

***MRDEC DIS TECHNOLOGY AND EXPERTISE PROVEN
IN THE MOST COMPLEX OF LIVE/VIRTUAL ENVIRONMENTS***